

## I OPERATING PRECAUTIONS

Please place the turntable on a horizontal support free of vibrations. For prevention of acoustical feedback, the speakers must be placed a sufficient distance from the turntable. Save packaging should shipping become necessary!

**Warning:** If turntable is not set for the power requirement in your area, adjust the selector switch as follows:

- 1) Turn the turntable platter until the selector switch shows through the hole of the platter (See Fig. 1).
- 2) Slide the switch actuator to the voltage indication corresponding to the power of your area.

## II ASSEMBLY/ADJUSTMENT

### Assembly:

- 1) Remove packing from tone arm and save for possible re-use.
- 2) To remove the headshell, simply twist the bayonet ring at the tonearm end one turn clockwise. The headshell will easily pull off end of tone arm.

Cartridge Mounting: (For supplied pickup, go to "Adjustment Of Tracking Force" and adjust for 2 grams - **The Stylus that is supplied mounted in cartridge is LP**). The extra supplied stylus is the 78 stylus.

Fasten the cartridge/pickup to the headshell. It is usually more convenient for screws to enter from cartridge side with nuts on top. Orient the pickup forward or to the rear by aid of the gauge provided. The cartridge body should be parallel to the lines at both radii as much as possible before tightening the screws. If in a hurry, towards the rear will suffice for most pickups. Wire as follows: green to right ground, blue to left ground, red to right, and white to left.

For convenience, you may wish to purchase an extra headshell/cartridge and change this combination instead of the styli.

### Adjustment Of Tracking Force:

- 1) Mount the cartridge headshell to the arm and lightly twist the retaining collar to hold it.
- 2) Set the Anti-Skate knob to "0." Remove stylus protective cover if present.
- 3) Set the cuing lever to the down position.
- 4) Release the arm clamp and move the tonearm to the space between the arm rest and the platter, taking care not to damage the stylus.
- 5) Adjust for balance by turning the counterweight either clockwise or counterclockwise (Fig. 3).
- 6) Return the tonearm to the arm rest and fasten the arm clamp.
- 7) Hold the counterweight at the adjusted position and turn the tracking force dial until the "0" mark is aligned with the index line on the tonearm shaft (Fig. 4).
- 8) Turn the counterweight/tracking force dial assembly counterclockwise till the desired tracking force is opposite the index line. We recommend 2.0 Grams minimum. For forces above 3.0 Grams, simply continue past the three for the additional force.

### Anti-Skating Adjustment

Set the anti-skate control (Fig. 5) to a position which corresponds to the adjusted tracking force. If the cartridge tracking force is adjusted for 2.5 Grams, the anti-skate control should also be set to 2.5.

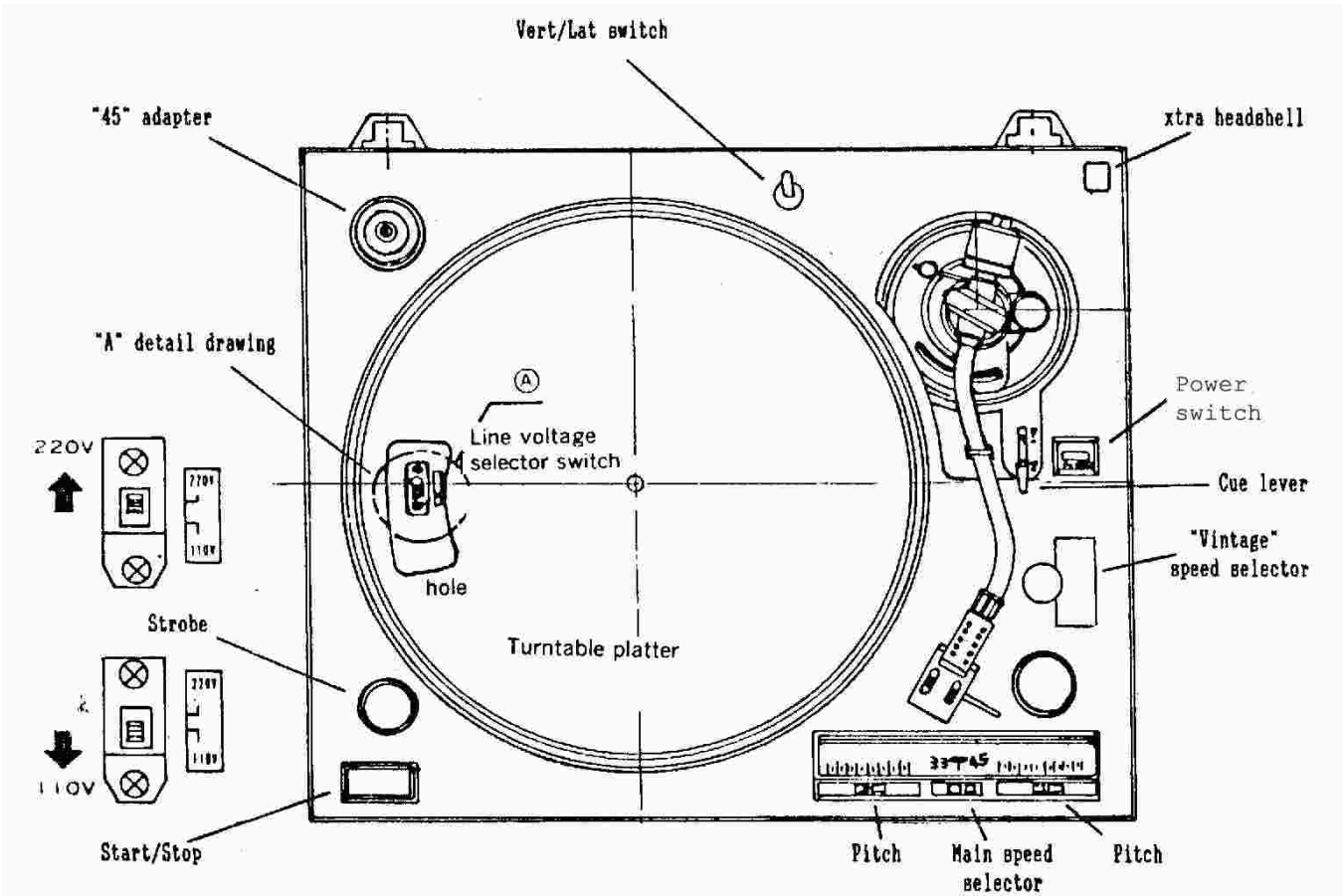

Fig. 1

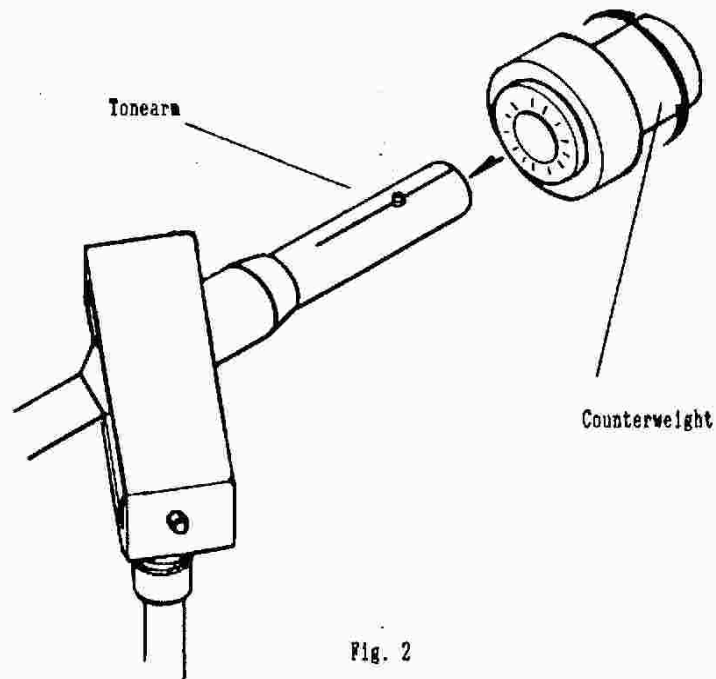

Fig. 2

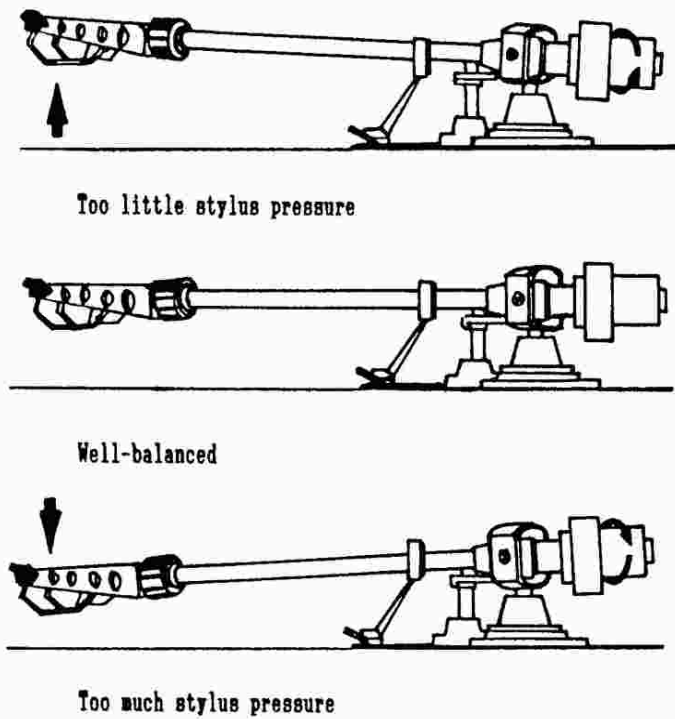

Fig. 3

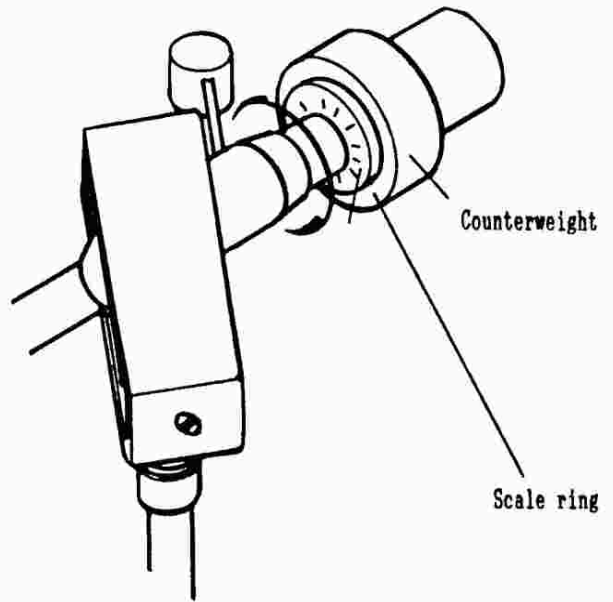

Fig. 4

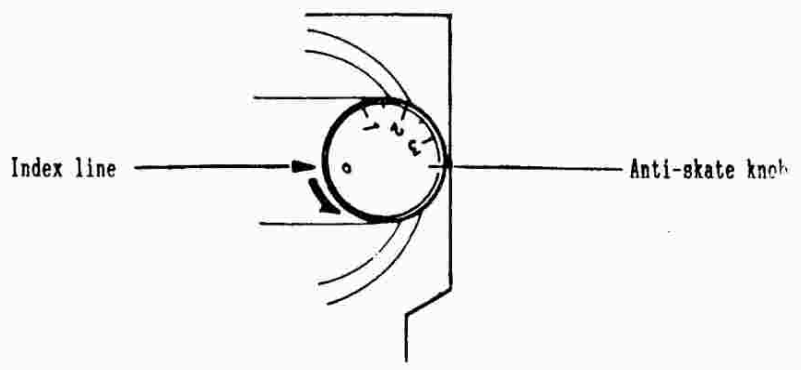

Fig. 5

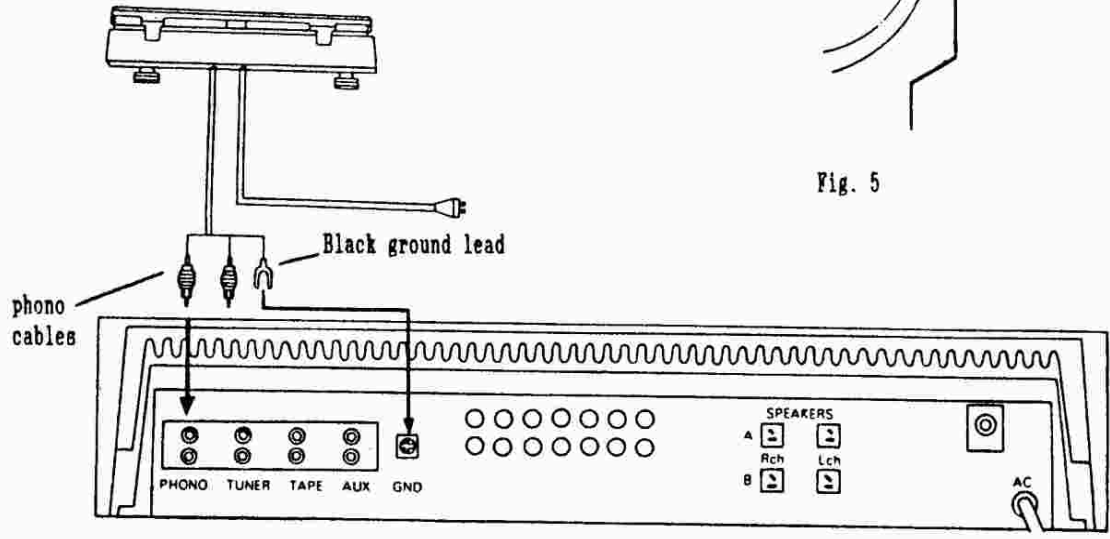

Fig. 6

### Adjustment Of The Platter Speed

- 1) For speeds 33 & 45, the Vintage Speed switch should be set to "45."
- 2) Slide the "Speed" switch to "33" or to "45." **NOTE: "45" adapter is mounted on push on tab at left rear.**
- 3) Press the "Power" button to On position.
- 4) Press the "Start/Stop" button firmly. Table will begin rotating.
- 5) For speeds 71 thru 80 rpm, the main "Speed" switch should be set to "45."
- 6) Calibrate 33 rpm speed by observing the strobe dots at edge of platter.
- 7) Adjust the "Pitch" control until the strobe dots appear stationary.
- 8) Use the supplied strobe disc with the selector adjusted to "78" rpm. Use the "45 Pitch" control and adjust it so that the strobe lines for "78" do not move. All other "Vintage" speeds will now also be in calibration.



### Connection

The phono cables and ground lead attach at turntable rear. Connect the gray plug to the amplifier left channel PHONO input and the red plug to the right channel input. Note: This must be a standard magnetic phono input. Others will not work! Connect the black ground lead to the amplifier ground terminal (Fig. 6). Finally plug the power cord into to power outlet. Orient it to minimize hum when the volume is moderately high.

### III OPERATION

Note: Space is provided on the right rear corner for storing one extra headshell.

### Suggested Speed Settings For Vintage Records

The setting of the Auxiliary "Vintage" speed selector switch converts the main "45" setting only. Do not use it with the main selector at "33." The following are recommended settings for vintage records:

71.29	Berliner, Early Victor (no label), Zonaphone
76.59	Acoustic Victor (many)
78.26	"Modern" "78's" (You will use this setting for almost all records 1930 to 1955)
80	Edison, Pathe vertical (paper label), acoustic Columbia & Okeh, Most vertical

### **Remember:**

- Set "speed" switch to 33 for LP's
- Set "speed" switch to 45 for "45's" or "78's"

### Playing A Record

- 1) Select the speed for the record to be played.
- 2) Place a record on the turntable platter - use the 45 adapter when playing a doughnut style record which has a large diameter center hole.
- 3) Move the Cuing lever to the up position.
- 4) Push the Start/Stop switch. Position the tonearm over the first groove of the record and move the cuing lever

to the down position. The tonearm will gently drop to the playing surface.

- 5) If you wish to stop play of a record, lift the arm off of the record.
- 6) At the end of the side, lift the arm off of the record surface and return it to rest position.

#### Record Cuing (especially useful when assembly editing on a tape recorder)

- 1) Engaging the stylus to the playing surface and rotate the platter manually to the beginning of sound desired (note: you may have to stop platter rotation by pressing Start switch).
- 2) Rotate platter by hand about 1/2 turn counterclockwise.
- 3) Push Start/Stop button.

#### IV OPTIONS

Vertical/Lateral Switch (Note: This option requires an extra-cost, optional cartridge, such as, Shure, Stanton, etc.)

The normal position for this switch is towards the colored dot. This corresponds to lateral cut records including stereo Lp's. To play a vertical cut record, such as an Edison or Pathe:

- 1) Move Vert/Lat switch actuator away from colored dot.
- 2) Set amplifier or preamplifier "mode" control or equivalent to "mono."
- 3) Play record same way as regular records.
- 4) To remove center solo performer from stereo record, set Vert/Lat switch away from dot and set amplifier "mode" control to mono. Monophonic recordings can be produced less these soloists in this manner.

#### Phono Cartridge

Wiring to the headshell is as follows: White(L), Red(R), Blue(LG), and Green(RG).

For reproduction of "78's" heavier tracking pickups are recommended. Pickups tracking at 3 - 6 grams will do no harm to these discs. Set tracking force to 3 grams, and set anti-skating 3 grams.

#### Problems

- |                              |  |
|------------------------------|--|
| <b>No belt</b>               | Check again. It's on the inside rim of the platter.  |
| <b>No platter rotation</b>   | Belt fell off of platter.  |
| <b>Very low sound output</b> | You have plugged the turntable into "Aux," not "Phono" inputs of your amplifier. You are using a low-cost amplifier whose "Phono" inputs are for amplified turntables. |
| <b>Hum or no sound</b>       | Check that the black ground wire is hooked between the turntable and the amplifier. Clean the headshell pins by rubbing them on a piece of cloth.                      |
| <b>Runs slow at 78</b>       | You forgot to set main speed to "45."  |
| <b>Belt off platter</b>      | Take "C" clip off spindle; pull off platter retrieve belt. Put on inside rim of platter, then replace platter.   |
| <b>Skipping</b>              | Increase tracking weight, experiment with adjustment of anti skating force.  |
| <b>Cartridge</b>             | Mount another cartridge in another headshell and shim it for proper alignment for use with that  |

**sets funny with some records** type of record. You may probably have to do this for Edison records.

**Stylus too tight** Stylus need not be pushed in all the way. Stop pushing when resistance builds. If "stuck," wiggle it gently while pulling out.

#### Further Considerations

Set "mode" control of amplifier mono for mono records. Similarly, the feed to a tape recorder (not affected by "mode" control) should be paralleled when making recordings. The right and left "tape output" of your amplifier may be combined with a "Y" connector set to accomplish this. This function along with proper record compensation for non-RIAA records is performed by the Esoteric Re-Equalizer.

#### V SPECIFICATIONS

Type: DC motor, belt drive	Hum & Noise (unweighted): -50 dB (ref. 7 cm/sec).
Speeds: 33.33, 45, 71.29, 76.59, 78.26, 80 rpm.	Wow and flutter: Less than 0.18 (WRMS).
Turntable platter: 11.82."	Tonearm: Statically balanced, S-shape, Manual.
Minimum recommended tracking force: 2.0 grams.	Dimensions: 16 1/2" X 13 3/4" X 4 1/2."
Power supply: 110/220 VAC, 60/50 Hz.	

#### - VINTAGE RECORDS -

Esoteric Sound regularly engages in selling vintage records by mail auction at reasonable prices. This includes "78" rpm records, LP's, broadcast transcriptions, broadcast and commercial tape recordings, and occasionally audio equipment. Please send a note if you wish to be included in our mailing list.

#### LIMITED WARRANTY

This product has been manufactured to precise standards and rigid quality control. Return authorization must be obtained before making any return. **Unit should be returned in it's original packing otherwise cost of repair for damage incurred will be charged.** We can advise you as to alternate proper packing should this not be available. Such returns should be accompanied by a payment of **\$9.00** shipping and handling. It is fully warranted against defective materials or workmanship under the normal use for the warranty period of 6 months from time of purchase to the original owner. Repairs, adjustment for defects or replacement of parts will be performed free of charge, except:

- a) If equipment has been damaged by accident or mishandling.
- b) If equipment has been serviced or modified by other than our authorized agents.
- c) In case of theft, loss, fire or other calamities by the Acts of God.

ESOTERIC SOUND  
1608 HEMSTOCK AVE.  
WHEATON, IL 60187  
VOICE/FAX: (630) 933-9801  
E-MAIL: EsotericTT@aol.com